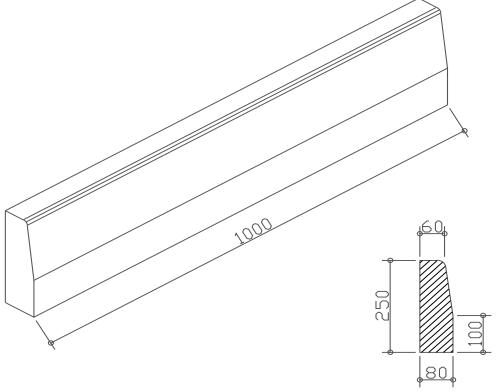
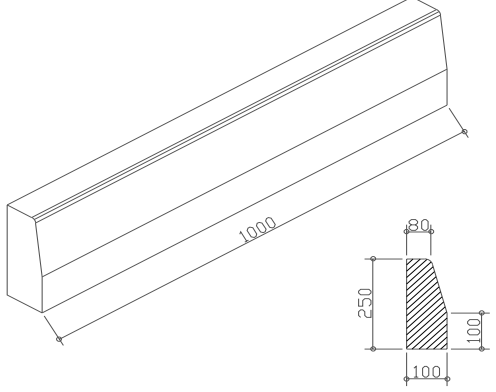
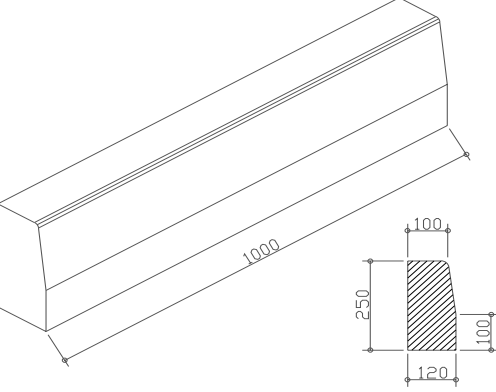
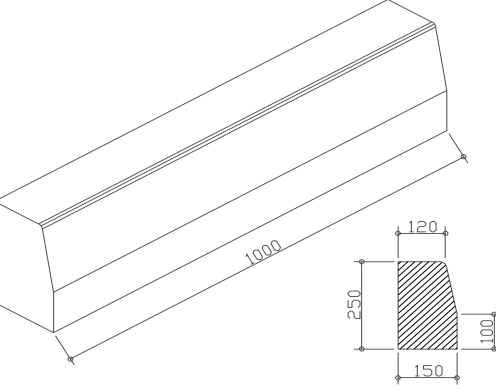
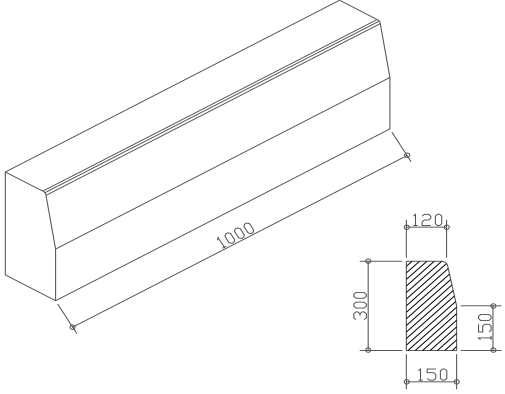
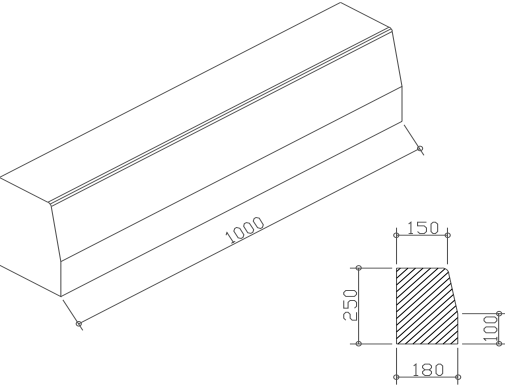
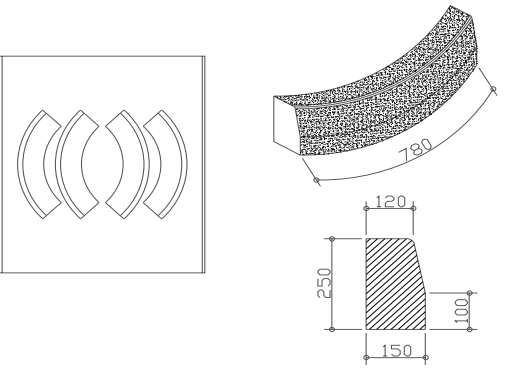
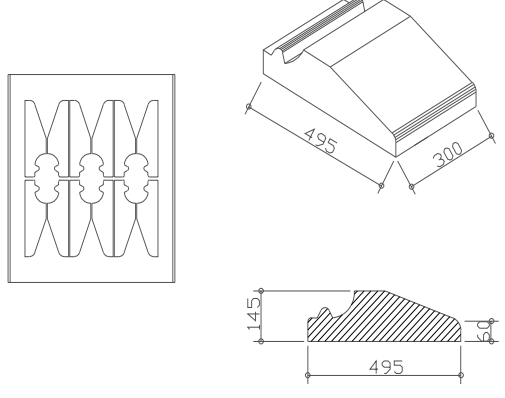

**for kerbstones  
and flat stones**

This catalogue is property of BADIN S.r.l. each illegal or unauthorised diffusion will be legally pursued

	<p><b>MOULD FOR KERBSTONES</b></p> <p>Dimensions of obtained element: <b>60/80 x 250 x 1000</b></p> <p>N° of elements each cast                    10 N° of special elements                        N/A</p> <p>Not applicable on 1012 and 1015</p> <p style="text-align: right;"><b>401</b></p>
	<p><b>MOULD FOR KERBSTONES</b></p> <p>Dimensions of obtained element: <b>80/100 x 250 x 1000</b></p> <p>N° of elements each cast                    9 N° of special elements                        N/A</p> <p>Not applicable on 1012 and 1015</p> <p style="text-align: right;"><b>402</b></p>
	<p><b>MOULD FOR KERBSTONES</b></p> <p>Dimensions of obtained element: <b>100/120 x 250 x 1000</b></p> <p>N° of elements each cast                    7 N° of special elements                        N/A</p> <p>Not applicable on 1012 and 1015</p> <p style="text-align: right;"><b>403</b></p>
	<p><b>MOULD FOR KERBSTONES</b></p> <p>Dimensions of obtained element: <b>120/150 x 250 x 1000</b></p> <p>N° of elements each cast                    6 N° of special elements                        N/A</p> <p>Not applicable on 1012 and 1015</p> <p style="text-align: right;"><b>404</b></p>

	<p><b>MOULD FOR KERBSTONES</b></p> <p>Dimensions of obtained element: <b>120/150 x 250 x 1000</b></p> <p>N° of elements each cast                    5 N° of special elements                        N/A</p> <p>Not applicable on 1012 and 1015</p> <p style="text-align: right;"><b>405</b></p>
	<p><b>MOULD FOR KERBSTONES</b></p> <p>Dimensions of obtained element: <b>150/180 x 250 x 1000</b></p> <p>N° of elements each cast                    4 N° of special elements                        N/A</p> <p>Not applicable on 1012 and 1015</p> <p style="text-align: right;"><b>406</b></p>
	<p><b>MOULD FOR KERBSTONES</b></p> <p>Dimensions of obtained element: <b>120/150 x 250 x 780</b></p> <p>N° of elements each cast                    4 N° of special elements                        N/A</p> <p>Not applicable on 1012 and 1015</p> <p style="text-align: right;"><b>407</b></p>
	<p><b>MOULD FOR KERBSTONES</b></p> <p>Dimensions of obtained element: <b>145/60 x 300 x 495</b></p> <p>N° of elements each cast                    12 N° of special elements                        N/A</p> <p>Not applicable on 1012 and 1015</p> <p style="text-align: right;"><b>408</b></p>

This catalogue is property of BADIN S.r.l. each illegal or unauthorised diffusion will be legally pursued

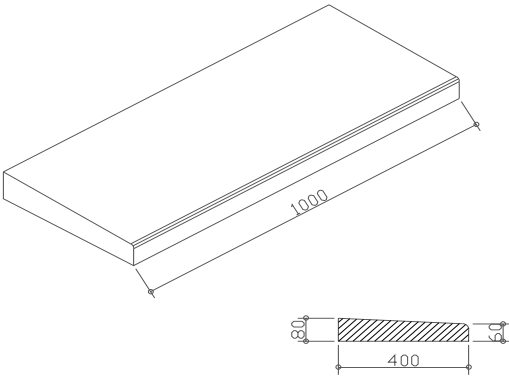
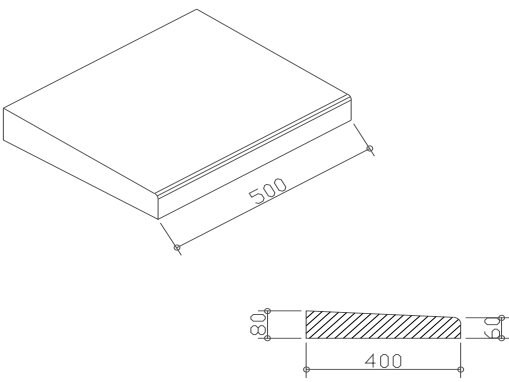
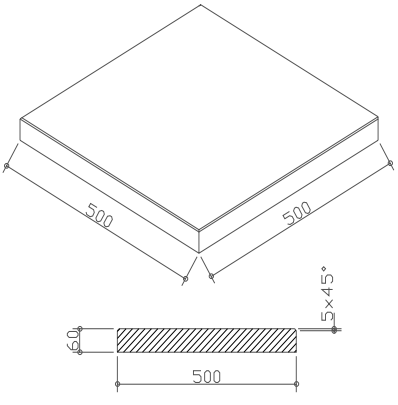
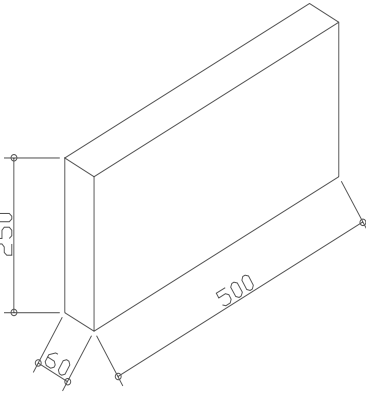
	<p><b>MOULD FOR FLAT STONES</b></p> <p>Dimensions of obtained element: <b>60/80 x 500 x 1000</b></p> <p>N° of elements each cast                    2 N° of special elements                        N/A</p> <p>Not applicable on 1012 and 1015</p> <p style="text-align: right;"><b>409</b></p>
	<p><b>MOULD FOR FLAT STONES</b></p> <p>Dimensions of obtained element: <b>60/80 x 400 x 500</b></p> <p>N° of elements each cast                    4 N° of special elements                        N/A</p> <p>Not applicable on 1012 and 1015</p> <p style="text-align: right;"><b>410</b></p>
	<p><b>MOULD FOR FLAT STONES</b></p> <p>Dimensions of obtained element: <b>500 x 500 x 60</b></p> <p>N° of elements each cast                    4 N° of special elements                        N/A</p> <p>Not applicable on 1012 and 1015</p> <p style="text-align: right;"><b>411</b></p>
	<p><b>MOULD FOR FLAT STONES</b></p> <p>Dimensions of obtained element: <b>250 x 500 x 60</b></p> <p>N° of elements each cast                    26 N° of special elements                        N/A</p> <p>Not applicable on 1012 and 1015</p> <p style="text-align: right;"><b>412</b></p>

This catalogue is property of BADIN S.r.l. each illegal or unauthorised diffusion will be legally pursued